

## DCG-01 Benchtop Gapper

The DCG-01 is a ferrite core gapper suitable for gapping sample cores in a laboratory. It's compact design, 12" W x 24" L X 8" H, fits comfortably on any work surface.

- Easy gap length adjustment.
- Quick change tooling for different core styles. Tooling prevents chipping of back and side walls of core and ensures a flat grind.
- Excellent repeatability.
- Operator friendly.
- Coolant is sprayed during the gapping process for a quality grind. Coolant reservoir includes a drain/outlet for coolant changes.

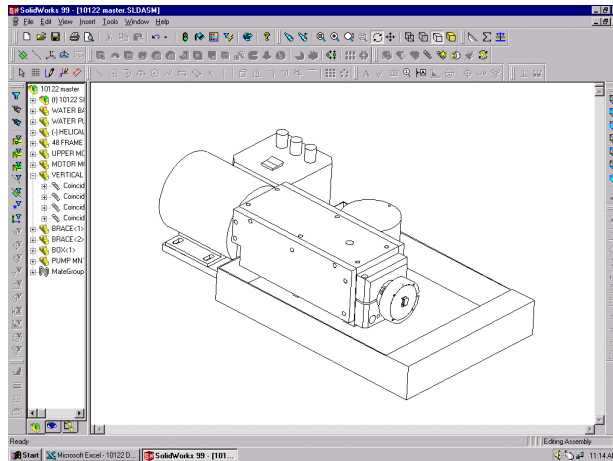

*A quality, economical gapping solution  
for prototype laboratories.*